

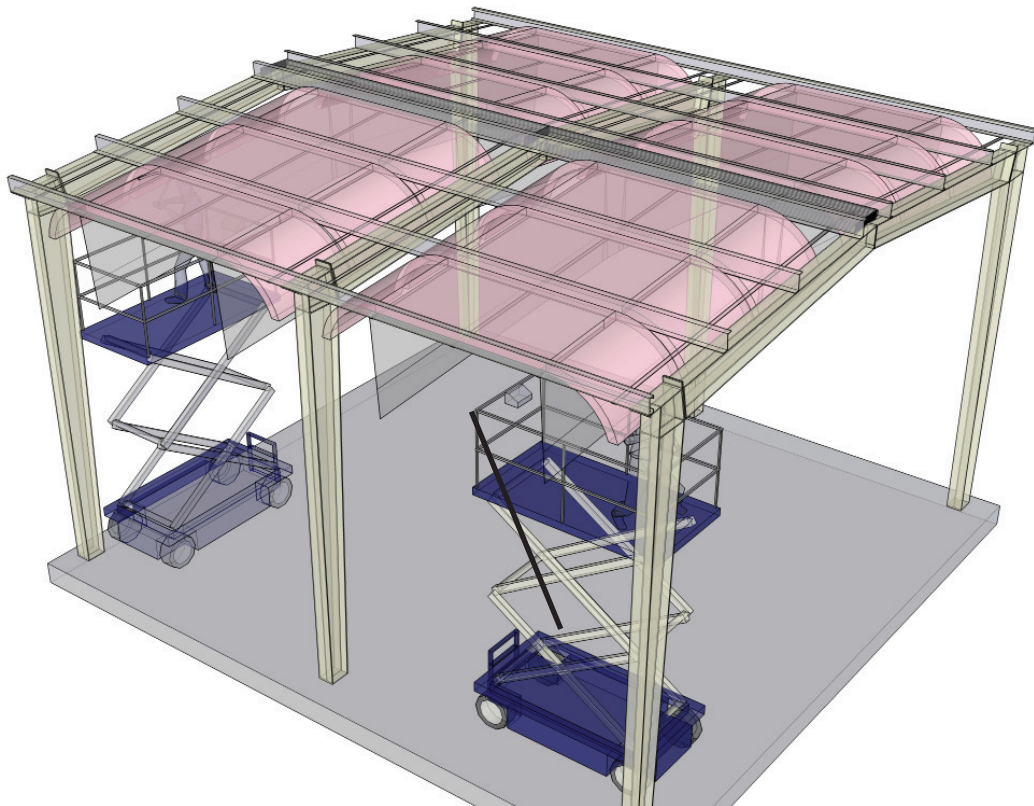

INNOVATIONS FOR LIVING®

Retrofit OptiLiner™ Banded Liner System



General

Introduction

The Owens Corning OptiLiner Banded Liner System is designed to provide maximum thermal performance in pre engineered metal buildings using Owens Corning metal building insulation. In addition to thermal performance, this system offers superior acoustics, finished appearance and brighter interior.

Safety Considerations

Installation contractor must have a site specific safety plan. Comply with all OSHA applicable local rules and regulations when installing this system. **WORKERS MUST USE OSHA REQUIRED FALL PROTECTION WHEN INSTALLING THE BANDED LINER SYSTEM AT HEIGHTS. (SEE OSHA REGULATIONS AT 29 CFR 1926, SUBPART M)**

Caution: Banding has sharp edges. Use caution when handling. Wear cut proof gloves.

Required Personal Protective Equipment: Safety glasses, cut proof gloves, long sleeve loose fitting clothing (for insulation installation)

Before You Start

- Open pallets and packaging to ensure complete order was received
- Review drawings to ensure each custom made fabric panel is installed in the appropriate area
- Obtain necessary rake angle for your building type
- Assemble appropriate equipment and tools
- Assure weather is appropriate to begin installation

Materials List

- Banding
- Adhesive and/or double faced tape
- Fabric panels
- Insulation per specification
- Fasteners
- Patch tape (if required)

Equipment and Tools Required

- Man lift / scissor lift./fall protection
- Safety glasses
- Screw gun
- Cut proof gloves
- Tape measure
- Locking clamps
- Razor knife
- Paint brushes
- Tin snips
- Banding dispenser
- Iron pipe for banding dispenser



INNOVATIONS FOR LIVING®

Retrofit OptiLiner™ Banded Liner System

Retrofit Installation Guide

Installation

Note Demonstration Only: Following are drawings which illustrate retrofit installation on a metal building from top view without roof panels.

Banding Schedule

Traversal Banding Perpendicular to Purlins.

Table I

Bay Width (feet)	# Bands for Main Area	# Bands 8 inches from Rafter	Total # of Bands for Bay
15-16	3	2	5
17-20	4	2	6
21-24	5	2	7
25-28	6	2	8
29-32	7	2	9
33-36	8	2	10
37-40	9	2	11
41-42	10	2	12

1. Determine the width of the bay and refer to Table I for number of bands required
2. Divide the bay into equal increments for installing main area banding 48" inches on center or less.

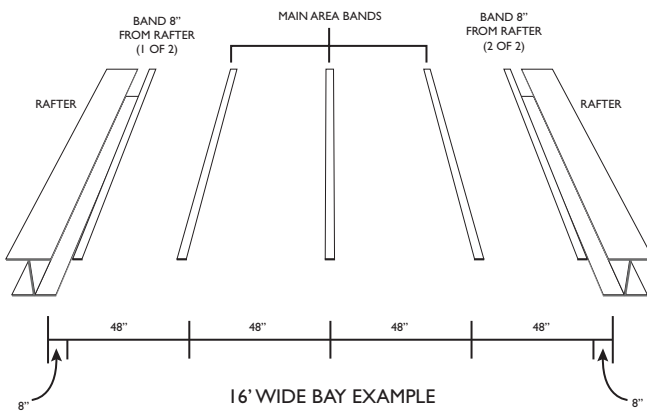

3. Locate one band 2" inches off each rafter in addition to the above banding.
4. Set-up rolls of steel band on the supplied dispenser to be dispensed perpendicular to purlins.
5. Cut bands to reach from eave-to-eave while accounting for roof pitch. Add one foot to each band for handling and fastening (refer to erection drawings).

6. Fasten one end of each traverse band to the bottom of sidewall eave strut using one fastener through the center of the eave strut.

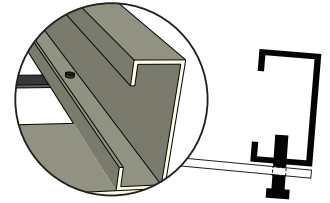

7. Pull each band hand tight to each ridge purlin and fasten with supplied screws. Finally pull each band hand tight to opposite

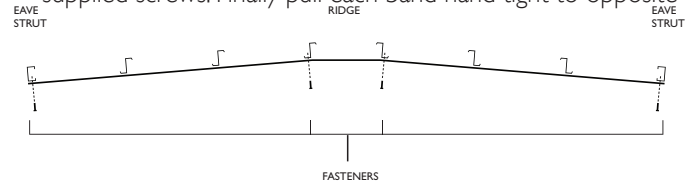

eave strut and fasten.

Note: If necessary, use a longitudinal band from end wall to end wall every 25 feet for traverse banding support during installation. Two longitudinal bands may also be used in the ridge area to provide additional support for fabric deployment. Remove longitudinal bands when complete.

BANDS

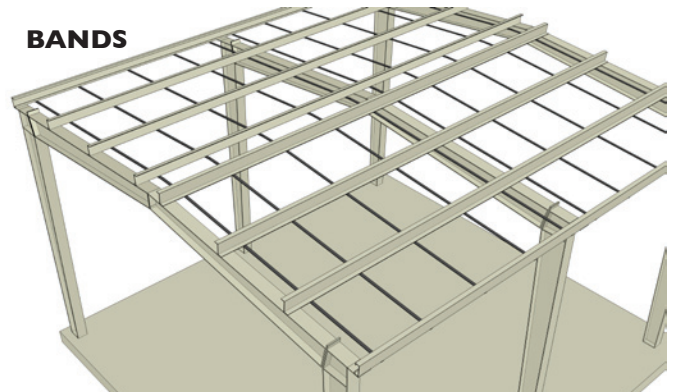

8. Sample final banding pattern.

Fabric Placement

Each Fabric Panel Sized and Fabricated For A Specific Space

Note: All building interiors are different due to various utility configurations and other obstructions. Please consult your OptiLiner provider in order to obtain proper custom panel fabrication for your building requirements.

1. Select the fabric panel designated for the bay or area in which you are working per supplied drawings.
2. Unwrap and begin feeding the "still folded" panel over the bands and between two purlins mid way in area to be covered.



INNOVATIONS FOR LIVING®

Retrofit OptiLiner™ Banded Liner System

Retrofit Installation Guide

Note: If installing white fabric, be sure to position the panel so that the white side will end up in the down position.

Figure 5

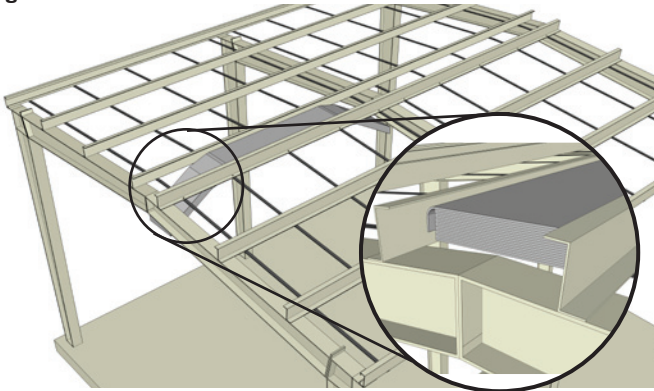

3. Pull the bottom leading edge of fabric toward the eave. Secure the fabric to the eave by:
 - a. Squaring fabric to the eave
 - b. Attach each band to the first purlin in from the eave.

Figure 6

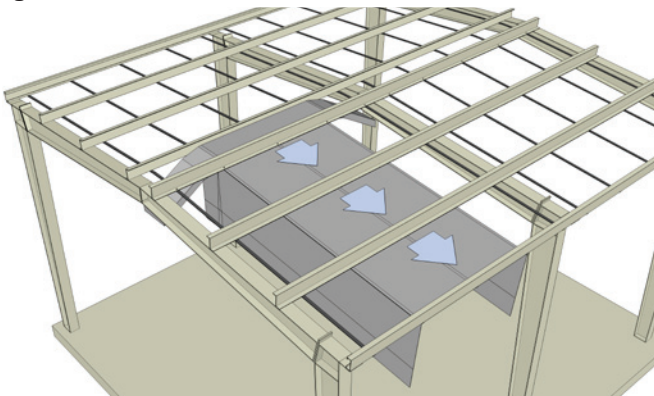

4. Continue the fabric installation by maneuvering the fabric over the banding below the purlins, across the entire bay and secure at the other eave. As in step #3

Figure 7

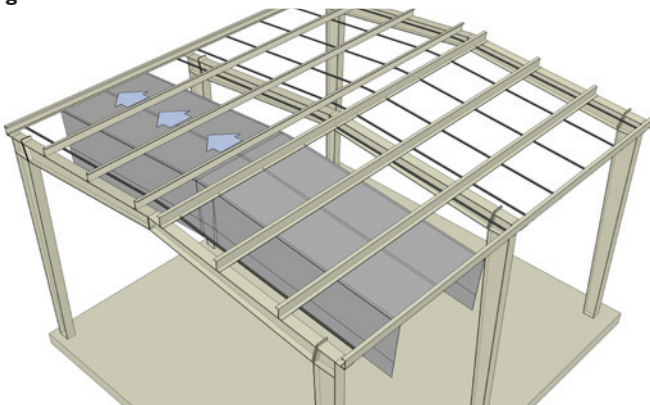

5. Back out each eave fastener.
6. Apply adhesive or double sided tape along the eave.
7. Adhere fabric to bottom of the eave.
8. Replace the fasteners and banding in the same holes in the eave through fabric.
9. Repeat for each band.

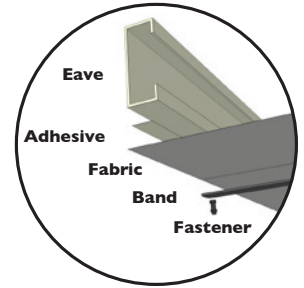

Complete the fabric installation by securing to the opposite eave as in step 2.

Figure 8

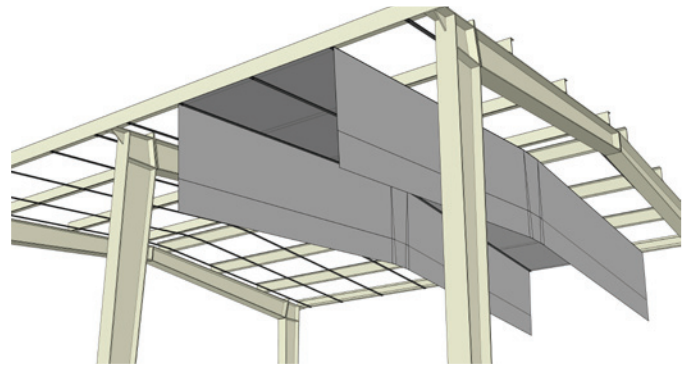

Install fasteners at each band/purlin intersection throughout the bay working wrinkles toward the rafters and eaves.

Figure 9

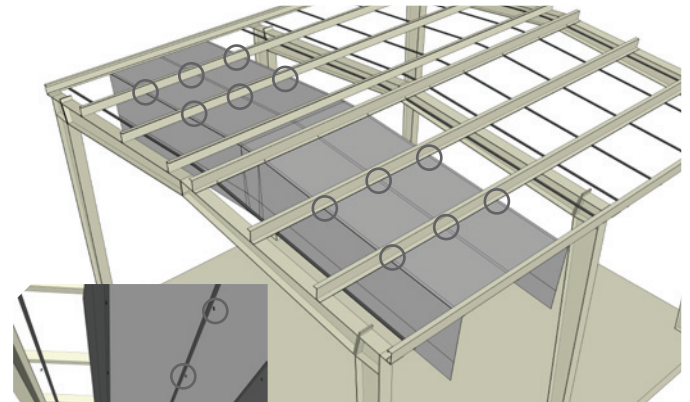



INNOVATIONS FOR LIVING®

Retrofit OptiLiner™ Banded Liner System

Retrofit Installation Guide

Rolled Blanket Insulation Installation

Select the custom cut roll of fiberglass to be installed in the cavity on which you are working. Attach the pulling mechanism to the fiberglass as demonstrated in Figure 9 below.

Figure 10

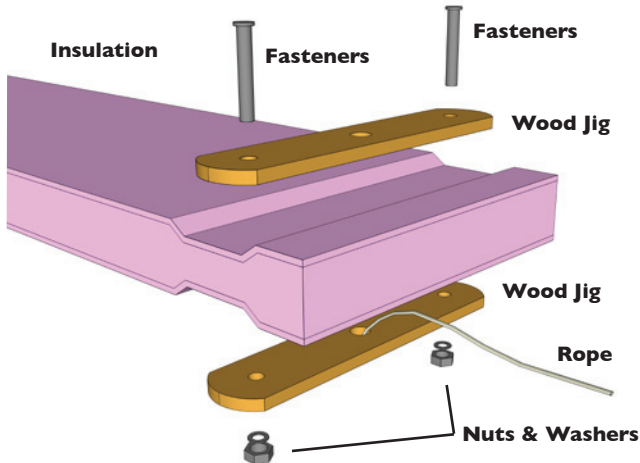

Once the pulling mechanism is attached to the fiberglass

1. The unattached rope end must be fed into the cavity between the purlins.
2. One person must then gently pull the unattached rope end while another person on the opposite end helps to guide the Fiberglass into the cavity.
3. Repeat for each purlin cavity. Figures 10, 11 & 12 demonstrate the fiberglass feed process.

Note: Each purlin cavity must be completely filled with fiberglass in order to maximize thermal performance. Purlin bracing may alter the method of installation.

Figure 11

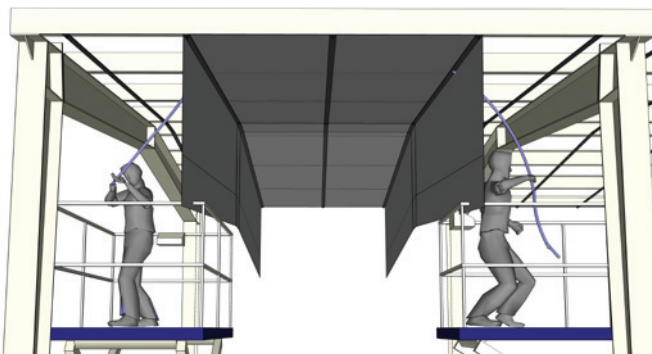

Figure 12

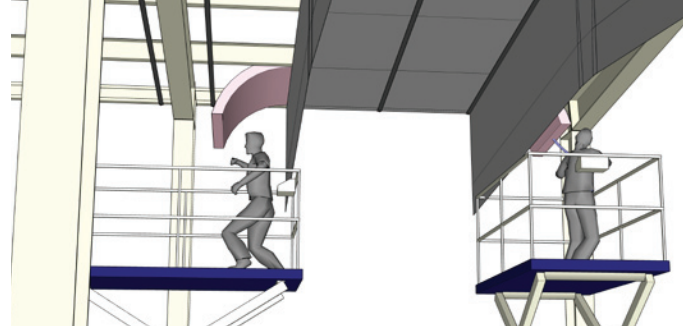

Figure 13

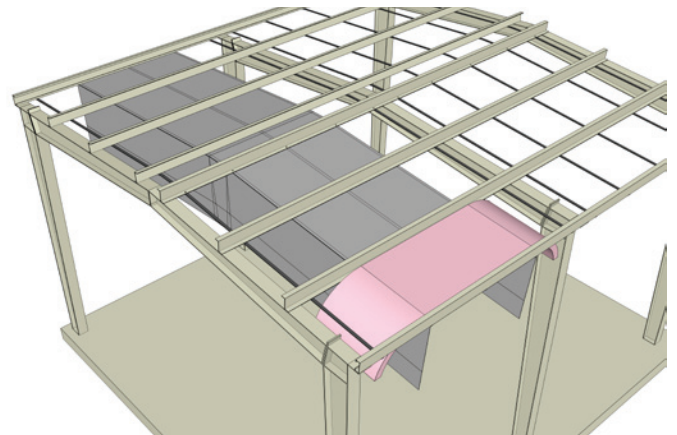
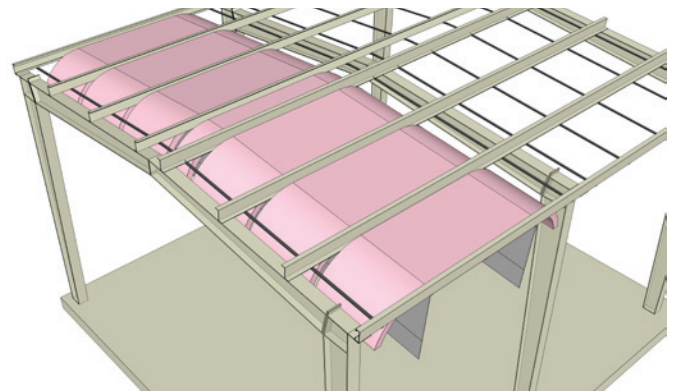

Figure 14





INNOVATIONS FOR LIVING®

Retrofit OptiLiner™ Banded Liner System

Retrofit Installation Guide

Blown In Loose Fill Fiberglass Insulation Installation

Blow OC Loose Fill Fiberglass into the cavity created on top of fabric and between existing insulation if present or bottom of the roof panels. Fill entire height and width of cavity.

Note: Seal one end of frameline prior to blowing in Owens Corning Loose Fill.

Upon completion of filling the cavities with fiberglass:

1. At rafter edge, feed fabric over the bands adjacent to and 2 inches from the rafters

Figure 15

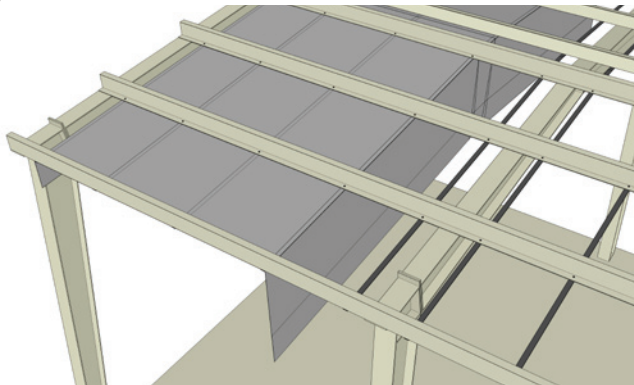
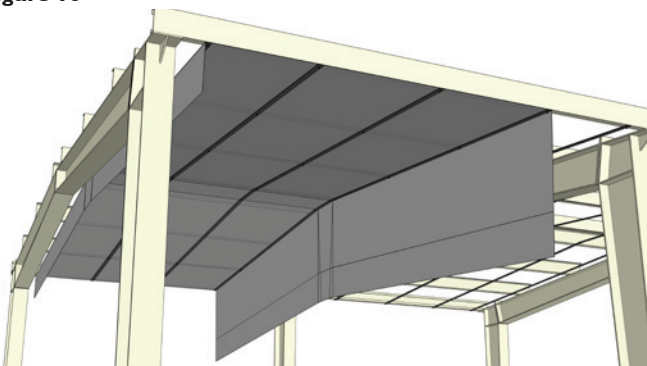
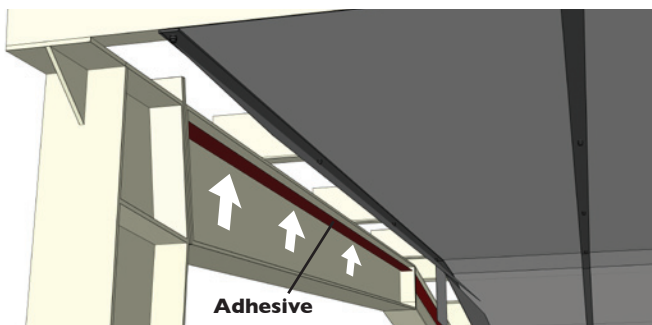

Figure 16



2. Apply adhesive or double faced tape to the bottom side of the upper flange on rafter

Figure 17



3. Pull fabric snugly and press against the newly applied adhesive or double faced tape

Figure 18

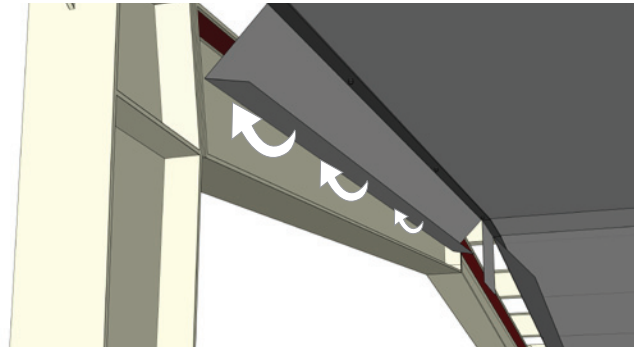

4. Trim excess fabric at the rafters and eaves.

Figure 19

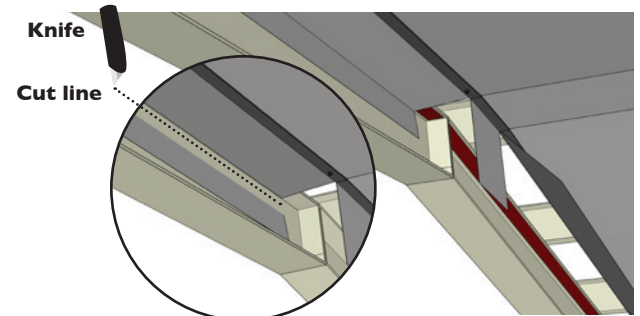

5. Complete the installation by sealing all holes and penetrations with supplied patch tape.

Wall Installation

Wall installation for retrofit will be the same as new construction except there is no foam tape installed on girts. Please refer to OC Pub # 10011266-A for details. Note that the thickness of the fiberglass rolled blanket installed should fill the cavity between the OptiLiner fabric and existing insulation if present or wall sheet.



INNOVATIONS FOR LIVING® www.owenscorning.com

OWENS CORNING INSULATING SYSTEMS, LLC
ONE OWENS CORNING PARKWAY
TOLEDO, OHIO, USA 43659
1-800-GET-PINK™

Pub. No. 10011267. Printed in U.S.A. March 2010. THE PINK PANTHER™ & ©1964–2010 Metro-Goldwyn-Mayer Studios Inc. All Rights Reserved. The color PINK is a registered trademark of Owens Corning. ©2010 Owens Corning.

